

Operations Manual

Series 70000 / RS70000 / E70000 Coaxial Relay

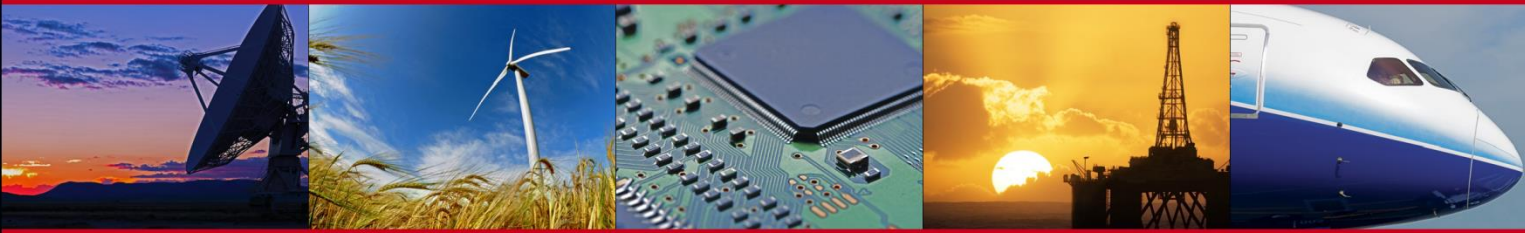

Communications - Telemetry - Automated Testing - Broadcast



Global Signal Switching and Distribution Specialists

Made in the USA

Warranty

This Universal Switching Corporation product is warranted against manufacturing defects and workmanship for a period of two years from the date of shipment from our factory. During this period, Universal Switching will, at its option, either repair or replace products which prove to be defective or out of specification per the original purchase order or contract. Damage by misuse or abnormal conditions of operation or evidence of partial or complete disassembly beyond normal maintenance or expansion procedures voids this warranty. Since Universal Switching Corporation has no control over conditions of use for the products it manufactures, no warranty is made or implied as to the suitability for the customer's intended use, beyond such performance specifications as are made a part of the purchase order or contract.

Equipment shipped F.O.B. Universal Switching Corporation shall become the property of the Buyer upon delivery to the carrier. Equipment shipped F.O.B. Destination shall become the property of the Buyer upon delivery acceptance from the carrier. Damage during shipment, for items shipped F.O.B. Universal Switching Corporation should be handled by immediately requesting the carrier's inspection upon evidence of damage to the equipment. This warranty excludes all other warranties expressed or implied. Universal Switching Corporation shall not be liable for any special, indirect, or consequential damages.

For warranty service or repair, the Buyer shall prepay shipping charges to Universal Switching Corporation, and Universal Switching Corporation shall pay shipping charges to return the product to the Buyer. However, Buyer shall pay all shipping charges, duties, and taxes for products returned to Universal Switching Corporation from another country.

Universal Switching Corporation warrants that its software and firmware designated by Universal Switching Corporation for use with an instrument will execute its programming instructions when properly installed on that instrument. Universal Switching Corporation does not warrant that the operation of the instrument, or software, or firmware will be uninterrupted or error-free.

CONTENTS

1.	INTRODUCTION TO THE SERIES XX70000 COAXIAL RELAYS	7
1.1.	Setup	8
1.2.	Preventing Electrostatic Discharges (ESD)	8
1.2.1.	Anti-Static Protection	8
1.3.	Serial Number Label	9
1.4.	Unpacking	9
1.5.	Installation and Removal	9
1.6.	Environmental Limits	10
1.6.1.	Storage and Shipping	10
1.6.2.	Operating Environment	10
1.6.3.	Installation Site Parameters	10
1.7.	Return Shipment	11
1.7.1.	Return Address	11
2.	SERIES 70000 COAXIAL RELAYS	13
2.1.	Series 70000 Model Number Definition	14
2.2.	Relay Enclosure Design Series 70000	15
2.2.1.	Cooling	15
2.2.2.	Mounting	15
2.2.3.	DB-25P Connector Pinout	16
3.	SERIES RS70000 / E70000 COAXIAL RELAYS	17
3.1.	Series RS70000 / E70000 Model Number Definition	18
3.2.	RS7000 Relay Enclosure Design	19
3.2.1.	Cooling	19
3.2.2.	Mounting	19
3.2.3.	DB-25P Connector Pinout J2	20
3.2.4.	Relay Interface/Driver Board	20
3.2.5.	Wall Mount Power Supply	21
3.2.6.	Typical Control Cable	21
3.3.	E70000 Relay Enclosure Design	22
3.3.1.	Cooling	22
3.3.2.	Mounting	22
3.3.3.	External Power Connector J1	23
3.3.4.	Ethernet Connector J2	23
3.3.5.	LED Indicators	23
3.3.6.	Wall Mount Power Supply	23

3.4. Programming the Series RS70000 / E70000	24
3.4.1. RS-232 Serial Control Parameters	24
3.4.2. Command Syntax and Operators	24
3.4.3. E70000 Default TCP/IP Settings	25
3.4.4. IEEE 488.2 Command Set	25
4. SERVICE	27
5. GENERAL SPECIFICATIONS	29
5.1. Typical Isolation	30
5.2. Insertion Loss – 2 throws to 24 throws	30
6. RECORD OF CHANGES	31

TECHNICAL SUPPPORT

Phone +1 818-381-5111

Fax +1 818-252-4868

Email support@uswi.com

7671 North San Fernando Road
Burbank, CA 91505-1073 USA



E70000 Series-10/100 Ethernet, LXI Compliant with PoE

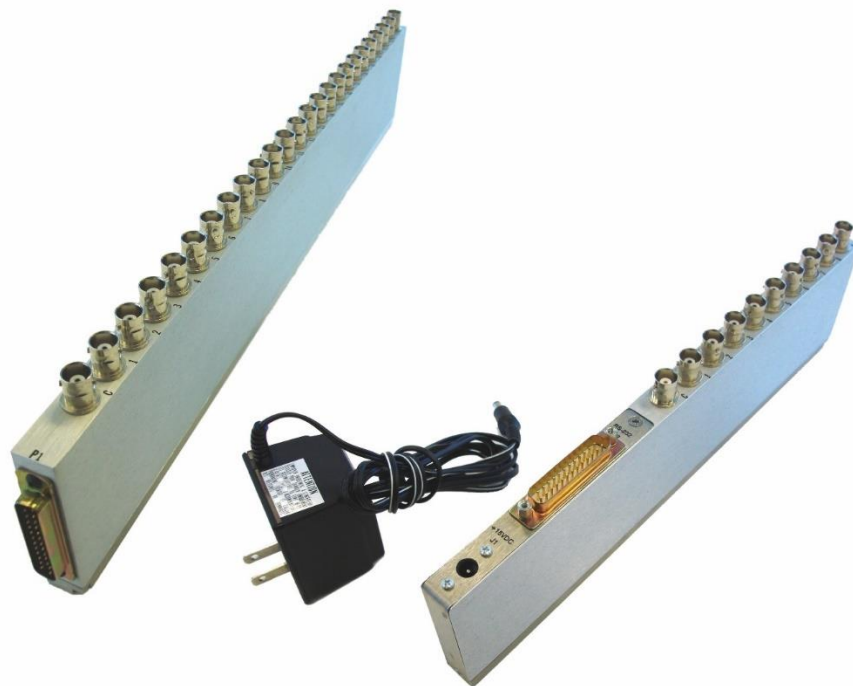

70000 Series (Left) and RS70000 Series (Right) with Serial RS-232 Control

1. Introduction to the Series xx70000 Coaxial Relays

The Series xx70000 Coaxial Relays are available in configurations from 2x1 up to 24x1. The series comes with standard voltage control, serial RS-232 control (RS70000) and Ethernet control (E70000). All the options are designed to maintain coaxial switching continuity over a wide range of critical applications. The relay housings are constructed of precision machined aluminum alloy for structural integrity and anodized for durability and corrosion resistance. Each signal path is a true coaxial path with switched center contacts. The covers are gasketed for maximum EMI protection. The basic reed switch elements are hermitically sealed in nitrogen filled gas envelopes and employ rhodium plated contacts to insure non-stick operation. The connector shields are continuous and are grounded to the housing.

The Series 70000 may be controlled alone by supplying the appropriate DC voltage at the appropriate connector pin or installed in a Model U11600 rack mount chassis complete with relay drivers, remote control ports and power supplies.

The Series RS70000 has a built-in serial control port and includes a wall mount power supply for standalone applications.

The Series E70000 has a built-in Ethernet control port and includes a wall mount power supply for standalone applications. Alternatively, the unit is Power over Ethernet (PoE) capable for a more streamlined installation.

Key features include the following:

- DC up to 800MHz frequency range (Model specific)
- DB-25P interface control connector
- BNC signal connectors standard
- Variety of configuration sizes
- Continuous shield
- Individual field replaceable relay contacts
- Extremely low EMI
- Low VSWR
- Optional signal connectors on some models
- Optional insulated and switched coaxial shields
- Optional coil suppression diodes on 70000 Series

1.1. Setup

This section contains cautions, notes and instructions on how to configure the Series xx70000 Coaxial Relays in preparation for operation.

It is important to follow the instructions in this section to assure safe and trouble-free operation. The information is provided to maximize the performance and expected lifetime of the relay module.

1.2. Preventing Electrostatic Discharges (ESD)

Electrostatic discharges (ESD) are the most severe form of electromagnetic interference. The human body can build up static charges that range up to many thousands volts. These build-ups can discharge very rapidly into an electrically grounded body or device. Damage to the internal components of a sensitive device can occur with just one static discharge.

The most common causes of ESD are the human body, low humidity, improper grounding, unshielded cables, and poor connections.

1.2.1. Anti-Static Protection

Electronic components can be damaged by electrostatic discharges (ESD). The technician handling the component must know about static electricity and how to protect the components from ESD.



CAUTION: All personnel must employ Anti-Static procedures and use Anti-Static protection at all times. Failure to observe this CAUTION could lead to damage to equipment.

1.3. Serial Number Label

The Series xx70000 coaxial relays have a unique factory assigned model number that defines the user requirements for a specific number of throws, coil voltage (if applicable), coil suppression diodes (if applicable), and optional connector type and insulated and switched coaxial shielding.

An identifying label is affixed on the end of the relay housing. The label contains both model number and unique serial number.

1.4. Unpacking

The Series xx70000 coaxial relays are packed in antistatic material and shipped in custom commercial packaging. Please pay attention when opening the shipping container so as not to inflict any cosmetic damage. Check the packing list against the contents of the shipping container.



NOTE: Carefully inspect the packaging for shipping damage and if present, immediately notify Universal Switching Corporation and the carrier. Keep all shipping materials for the carrier's inspection.

If the contents are not complete, or there is any kind of mechanical damage or visible defects, you must notify the factory within five (5) days of receipt.

1.5. Installation and Removal

The Series 70000 coaxial relays may be installed in a standard model 11600 mainframe, or operated standalone by providing a control voltage and return directly to the switch control connector. Attaching hardware is available on request.

The Series RS70000 coaxial relays are designed for standalone operation using simple RS232 remote control. A +15VDC power source is required and is provided by the included universal AC wall mount power supply.

The Series E70000 coaxial relays are designed for standalone operation using Ethernet remote control. Power is provided via the integrated PoE Ethernet port or optionally, a user can connect an external power supply via the two position header (TE: 147323-1).

1.6. Environmental Limits

You may operate the coaxial relays in a normal laboratory environment, production environment, or a more rugged industrial environment without any additional considerations. Protection should be provided against temperature extremes (shock), which can cause condensation.

1.6.1. Storage and Shipping

The coaxial relays may be stored or shipped in environments with the following limitations:

- Temperature: -20 degrees C to +60 degrees C
- Humidity: 0 to 98% (non-condensing)
- Altitude: 50,000 feet

1.6.2. Operating Environment

The coaxial relays may be used in any environment with the following limitations:

- Temperature: 0 degrees C to +50 degrees C
- Humidity: 0 to 98% (non-condensing)

1.6.3. Installation Site Parameters

The area in which the coaxial relay is to be operated should be as clean as possible. An environmentally controlled area is recommended.

1.7. Return Shipment

If a Series xx70000 coaxial relay is to be shipped back to the factory for service or modification, it is recommended that the original custom commercial packaging be used. Attach a tag identifying the current owner (including address and phone number) model and serial number of the coaxial relay or component, as well as a brief description of the required service or suspected problem.

Mark the container **FRAGILE** to help insure safe handling by the carrier. In correspondence, refer to the return item by the model number and serial number.



NOTE: Please call the factory prior to returning a relay. Return is not always necessary as many problems may be solved over the phone. If return is necessary, the factory shall assign an RMA number. No returned unit shall be accepted without an RMA number.

1.7.1. Return Address

When returning the module for repair or service, please use the following address:

Universal Switching Corporation
7671 North San Fernando Road
Burbank, CA 91505-1073 USA



NOTE: Additional information is available at the Universal Switching Corporation website: www.uswi.com

**THIS PAGE WAS
INTENTIONALLY LEFT
BLANK**

2. Series 70000 Coaxial Relays

The Series 70000 coaxial relay provides high performance and advanced features for best signal and connection reliability. They deliver compact switching technology in a rugged package design. This section describes the features and structural design qualities of the Series 70000 coaxial relays.

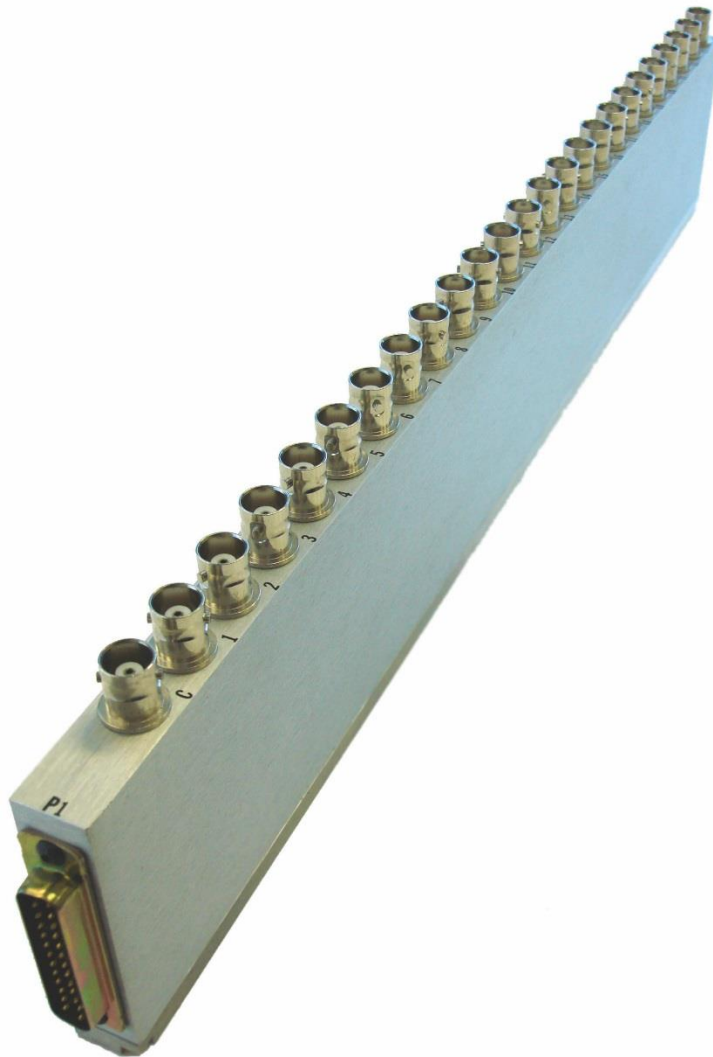

2.1. Series 70000 Model Number Definition

The model number defines the contact configuration, number of throws, coil voltage, and options such as coil suppression diodes, custom connectors (SMA, TNC, F-type), and insulated switched coaxial shields. For ordering, all part numbers are prefaced with “U” and break down as follows:

Part number: U 7 **(CC)** **(NT)** - **(V)** **(D)** **(X)**

(CC) Contact configuration

- 10 - Standard configuration (normally open) 100VDC, 250ma, 10W
- 25 - Standard (self-terminating type, 50 ohm) 4VDC, 250ma, 1/3W
- 27 - Standard (self-terminating type, 75 ohm) 4VDC, 250ma, 1/3W
- 30 - Medium isolation (normally open) 100VDC, 250ma, 10W
- 40 - High isolation (normally open) 28VDC, 250ma, 3W
- 65 - High isolation (self-terminating type, 50 ohm) 4VDC, 250ma, 1/3W
- 67 - High isolation (self-terminating type, 75 ohm) 4VDC, 250ma, 1/3W
- 70 - Mercury wetted* (normally open) 500VDC, 2A, 50W
- 90 - Standard with Triaxial connector (BJ-77) 100VDC, 250ma, 10W

* Due to environmental laws, mercury wetted contacts may not be available.

(NT) Number of throws

- | | | |
|----------|-----------|-----------|
| 02 - 2x1 | 08 - 8x1 | 16 - 16x1 |
| 04 - 4x1 | 12 - 12x1 | 24 - 24x1 |

(V) Coil voltage

- 1 - 24VDC to 28VDC (1,000 ohm coils)
- 2 - 15VDC (500 ohm coils)
- 5 - 5VDC (250 ohms coils) only for contact types 10 -30

(D) Coil suppression diodes

- 0 - Not included
- P - Suppression diodes included with coil common positive
- N - Suppression diodes included with coil common negative

(X) Extra options

- A - SMA signal connectors (on contact types 10, 25, 27, 65)
- C - Normally closed contacts to position 1
- F - F-type signal connectors (on contact types 10, 27)
- I - Insulated coaxial shield (on contact types 10, 25, 27, 70)
- L - Lockscrews on control connector so mate can be secured.
- S - Insulated and switched coaxial shield (on contact type 10, 25, 27, 70)
- T - TNC signal connectors (only on contact types 10, 25, 65)



NOTE: Suffix numbers not identified in this table indicate custom configurations. Refer to the module outline diagram that shipped with your product or contact the factory for additional information.

2.2. Relay Enclosure Design Series 70000

The Series 70000 coaxial relay design uses a machined aluminum alloy enclosure that is anodized for durability and corrosion resistance. The design of the enclosure provides a rigid framework that houses a collection of components including wiring, coils, reed switches, PCB, and BNC connectors. The gasketed mounting base is plated electroless nickel for conductivity.

2.2.1. Cooling

The Series 70000 coaxial relays are cooled by convection. No fans are required.

2.2.2. Mounting

Mounting is achieved by securing to the baseplate using #8-32 machine screws.

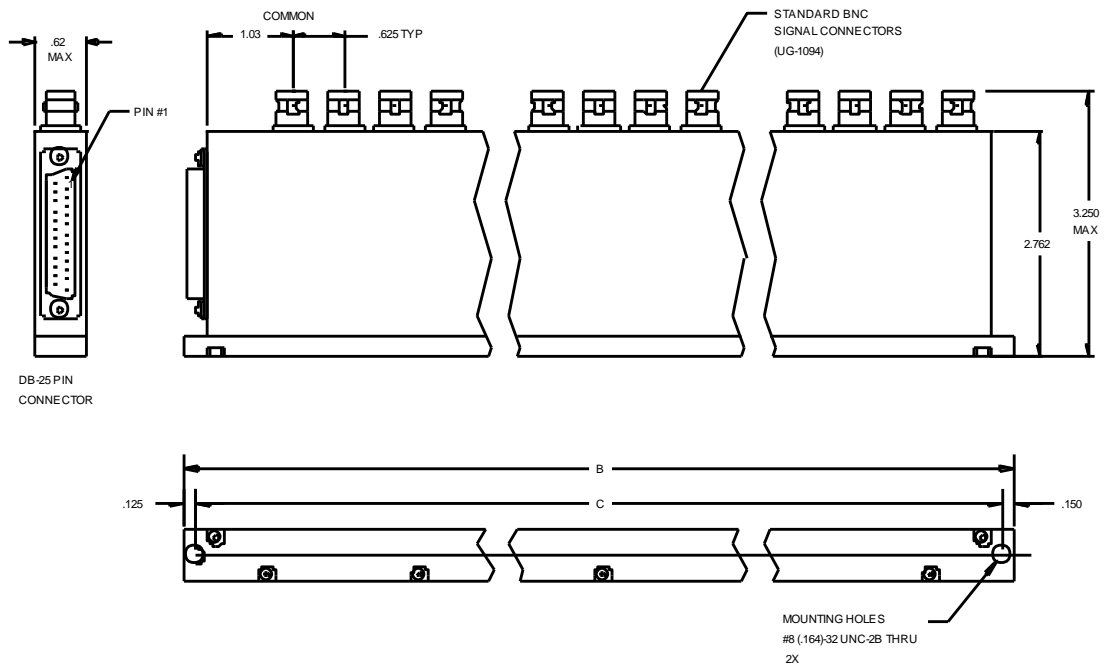

Dimension Table		
Model	B	C
7XX02	3.261	2.986
7XX04	4.511	4.236
7XX08	7.011	6.736
7XX12	9.511	9.236
7XX16	12.011	11.736
7XX24	17.011	16.736

2.2.3. DB-25P Connector Pinout

The Series 70000 coaxial relays utilize a DB-25P connector for power to individually control each port. The table below lists the pinout. Select the appropriate pins according to the coaxial relay configuration.

DB-25P Connector Pin Out	Signal Name
1	Port 1
2	Port 2
3	Port 3
4	Port 4
5	Port 5
6	Port 6
7	Port 7
8	Port 8
9	Port 9
10	Port 10
11	Port 11
12	Port 12
13	Port 13
14	Port 14
15	Port 15
16	Port 16
17	Port 17
18	Port 18
19	Port 19
20	Port 20
21	Port 21
22	Port 22
23	Port 23
24	Port 24
25	Common

Though more than 1 port may be connected simultaneously, there is no impedance matching or gain correction circuitry included. Connecting multiple ports may impact the gain, impedance, and quality of the signal by introducing multiple loads to the source signal.

For best performance, we suggest only connecting to one port at any given time.

3. Series RS70000 / E70000 Coaxial Relays

This section describes the features and structural design qualities of the Series RS70000 and E70000 coaxial relays. The RF portion of the relay modules are constructed the same as the 70000 series, but with added control features.



3.1. Series RS70000 / E70000 Model Number Definition

The Series RS70000 / E70000 model number defines the contact configuration, number of throws, and options such as custom connectors (SMA, TNC, F-type), and insulated switched coaxial shields. For ordering, all part numbers are prefaced with "U" and break down as follows:

Part number: U RS7 / E7 **(CC)** **(NT)** - **(X)**

(CC) Contact configuration

- 10 - Standard configuration (normally open) 100VDC, 250ma, 10W
- 25 - Standard (self-terminating type, 50 ohm) 4VDC, 250ma, 1/3W
- 27 - Standard (self-terminating type, 75 ohm) 4VDC, 250ma, 1/3W
- 30 - Medium isolation (normally open) 100VDC, 250ma, 10W
- 40 - High isolation (normally open) 28VDC, 250ma, 3W
- 65 - High isolation (self-terminating type, 50 ohm) 4VDC, 250ma, 1/3W
- 67 - High isolation (self terminating type, 75 ohm) 4VDC, 250ma, 1/3W
- 70 - Mercury wetted* (normally open) 500VDC, 2A, 50W
- 90 - Standard with Triaxial connector (BJ-77) 100VDC, 250ma, 10W

* Due to environmental laws, mercury wetted contacts may not be available.

(NT) Number of throws

- 02 - 2x1
- 04 - 4x1
- 08 - 8x1
- 12 - 12x1
- 16 - 16x1
- 24 - 24x1

(X) Extra options

- A - SMA signal connectors (on contact types 10, 25, 27, 65)
- C - Normally closed contacts to position 1
- F - F-type signal connectors (on contact types 10, 27)
- I - Insulated coaxial shield (on contact types 10, 25, 27, 70)
- S - Insulated and switched coaxial shield (on contact type 10, 25, 27, 70)
- T - TNC signal connectors (only for contact types 10, 25, 65)
- W - Wall mount power supply (Optional for the E70000 series)

 **NOTE: Suffix numbers not identified in this table indicate custom configurations. Refer to the module outline diagram that shipped with your product or contact the factory for additional information.**

3.2. RS7000 Relay Enclosure Design

The Series RS70000 coaxial relay design uses a rectangular machined aluminum alloy enclosure that is anodized for durability and corrosion resistance. The design of the enclosure provides a rigid framework that houses a collection of components including wiring, coils, reed switches, serial interface board with power and control connectors, PCB, and BNC signal connectors. The gasketed mounting base is plated electroless nickel for conductivity.

3.2.1. Cooling

The Series RS70000 coaxial relays are cooled by convection. No fans are required.

3.2.2. Mounting

Mounting is achieved by securing to the baseplate using #8-32 machine screws.

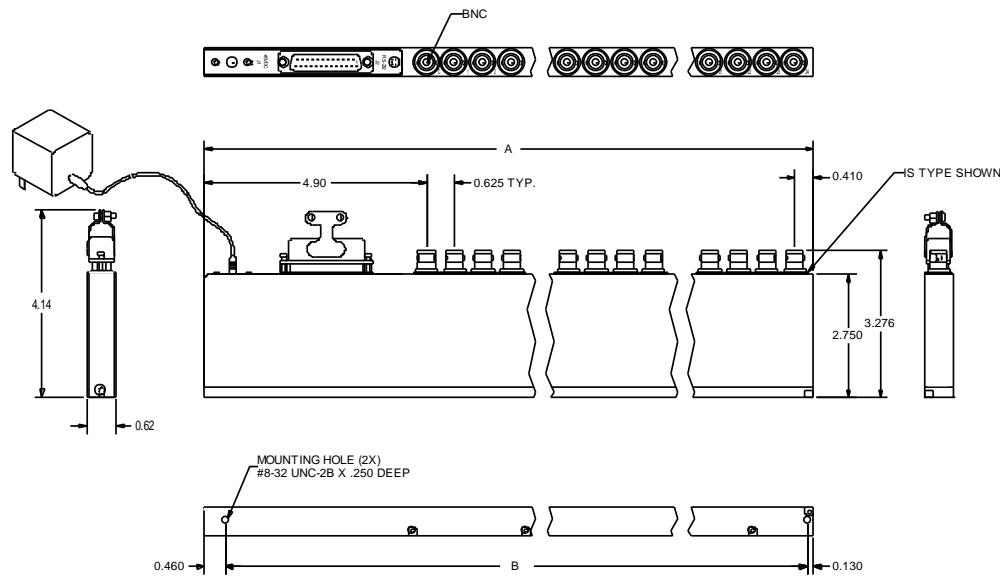

Dimension Table		
Model	A	B
URS7XX02	6.56	5.97
URS7XX04	7.81	7.22
URS7XX08	10.31	9.72
URS7XX12	12.81	12.22
URS7XX16	15.31	14.72
URS7XX24	20.31	19.72

3.2.3. DB-25P Connector Pinout J2

The Series RS70000 coaxial relays utilize a DB-25P connector. The table below lists the pinout for serial control.

DB-25P Connector Pin Out	Signal Name
2	Transmit (TXD)
3	Receive (RXD)
7	Signal Ground (SG); voltage return
1	Frame Ground (FG)
9	+12 VDC input (URS79000-12846A Only)

3.2.4. Relay Interface/Driver Board

The Series RS70000 coaxial relays utilize an Interface/Driver board to provide latching and coil drive for the relays. The RS70000 coaxial relay module must be connected to a RS-232C port.

The control input connector is a DB-25P connector (J2). The output connector is the PCB edge with gold plated contacts. The interface/driver board plugs into Series RS70000 coaxial relay and mates with a Cinch 50-30C-10 connector within the coaxial relay module. The interface/driver board receives power from the connector labeled J1. Note that on the URS79000-12846A model, J1 is capped and the unit receives +12V DC power via pin 9 on J2 with the voltage return on pin 7.

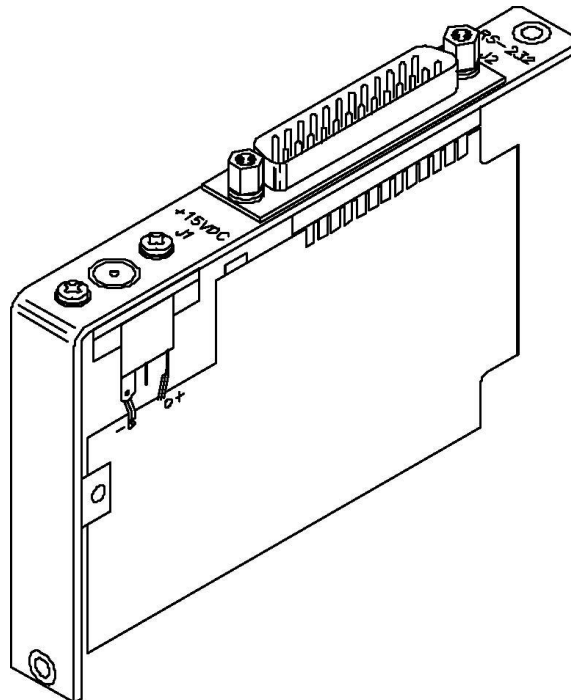

3.2.5. Wall Mount Power Supply

Supplied with the unit is a universal AC/DC wall-mount power supply. It accepts any AC input from 90-264VAC (47-63Hz) and provides +15VDC power for use with the RS70000 relay module.

Though the RS70000 ships with this power supply included, any quality 15VDC power source (0.6A min) can be used to power the unit. The suggested connector is a standard 2mm post jack (5mm diameter with a 2.1mm aperture and a 10mm minimum length) wired with the center post negative.

The power connector (J1), as well as the serial interface (J2), are conveniently located on the top of the Series RS70000 coaxial relay housing.

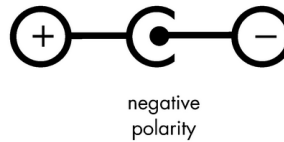

 **NOTE: The URS79000-12846A runs off of 12VDC and is powered on PIN 9 of J2 with the voltage return on PIN 7**

3.2.6. Typical Control Cable

A typical control cable consists of a DB-25 connector for the relay side and a DB-9 connector for the controller (computer) side. Below is a wiring diagram. Various length cable assemblies are available for purchase from Universal Switching. Please contact the factory for more details.

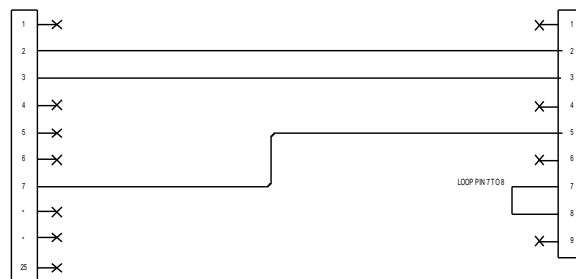
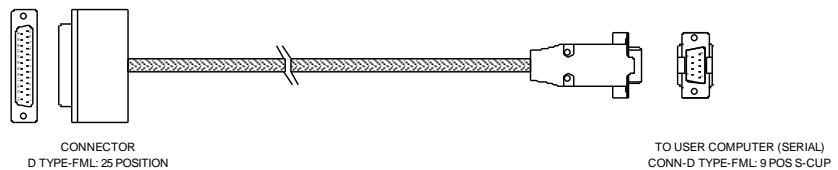

3.3. E70000 Relay Enclosure Design

The Series E70000 is 10/100 Ethernet and LXI compliant. It uses a rectangular machined aluminum alloy enclosure that is anodized for durability and corrosion resistance. The design of the enclosure provides a rigid framework that houses a collection of components including wiring, coils, reed switches, Ethernet interface board with integrated PoE, optional external power connector, PCB, and BNC signal connectors. The gasketed mounting base is plated electroless nickel for conductivity.



3.3.1. Cooling

The Series E70000 coaxial relays are cooled by convection. No fans are required.

3.3.2. Mounting

Mounting is achieved by securing to the baseplate using #8-32 machine screws.

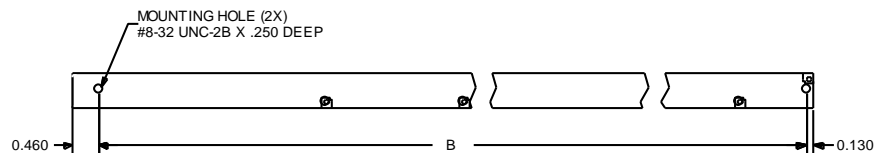

Dimension Table		
Model	A	B
UE7XX02	6.56	5.97
UE7XX04	7.81	7.22
UE7XX08	10.31	9.72
UE7XX12	12.81	12.22
UE7XX16	15.31	14.72
UE7XX24	20.31	19.72

3.3.3. External Power Connector J1

The E70000 is equipped with Power over Ethernet. However, an optional external power connector is provided for use the W option of the series (external wall mount power supply).

The connector is a TE: 147323-1, two position latching with pin 1 connecting to +V and pin 2 connecting to ground. A 15V DC power source is required.

3.3.4. Ethernet Connector J2

The Ethernet connector port is 10/100 and is LXI compliant. It is also Power over Ethernet (PoE) capable, for a more streamlined installation.

Available TCP/IP ports are 7145, 7147, 7149, 7151 and 7153.

3.3.5. LED Indicators

The standard Ethernet activity (Act) and link (Lnk) LED's are provided on the driver assembly. A green Lnk LED indicates connectivity while a flashing yellow Act LED indicates Ethernet traffic to/from the assembly

3.3.6. Wall Mount Power Supply

An optional universal AC/DC wall-mount power supply is available on units with a -W option. It accepts any AC input from 90-264VAC (47-63Hz) and provides +15VDC power for use with the E70000 relay module.

3.4. Programming the Series RS70000 / E70000

The standard remote-control command set consists of three (3) ASCII characters followed by a carriage return [CR].

There are three (3) possible operations: **S**, **R**, **CLR**

- **S** Set to energize a port
- **R** Re-Set to de-energize a port
- **CLR** Clear all to clear all connections
- **Q** Query to verify a port (only available on URS79000-12846A models)

3.4.1. RS-232 Serial Control Parameters

The serial control parameters are 9600 baud, no parity, 8 data bits, and 1 stop bit.

3.4.2. Command Syntax and Operators

Commands are sent using standard ASCII strings, upper case and three (3) characters in length. All commands end with a carriage return [CR]. The port numbers range from 01 to 24 depending on relay module configuration.

- Example to Set (energize) port -01: **S01[CR]**
- Example to Re-Set (de-energize) port-01: **R01[CR]**
- Example to clear connections: **CLR[CR]**
- Example to verify port -01: **Q01[CR]**
 - If de-energized (connected), this command will return **C01[CR]**. If energized (terminated), this command will return **D01[CR]**.

When successful, the command is echoed back with the exception of the Q command. Unsuccessful commands return the following errors:

- E01 for unrecognized command
- E02 for port less than 01 or greater than 24

Though more than 1 port may be connected simultaneously, there is no impedance matching or gain correction circuitry included. Connecting multiple ports may impact the gain, impedance, and quality of the signal by introducing multiple loads to the source signal.

For best performance, we suggest only connecting to one port at any given time.

3.4.3. E70000 Default TCP/IP Settings

The E70000 ships from the factory with the following default settings:

DHCP Mode: OFF
IP Address: 192.168.0.100
Subnet Mask: 255.255.0.0
Gateway: 192.168.0.1

To access the web GUI to change these default settings, set a laptop or PC to the same IP settings with the exception of the IP address. Use 192.168.0.101 instead, for example.

Using a standard CAT5 cable, plug directly into the Ethernet ports on both the laptop and E70000 and type 192.168.0.100 into an internet browser.

You should now have access to the web GUI. By selecting the LAN Configuration menu on the left hand side, you can access this password protected menu to set your desired information.

The default user name and password for this menu is below:

Username: admin
Password: secret

3.4.4. IEEE 488.2 Command Set

The IEEE 488.2 command set is thoroughly documented in the Programmers Guide – C3 Controllers. The user can enable this command set in place of the standard set via the web GUI interface's LAN configuration page.

Available TCP/IP ports are 7145, 7147, 7149, 7151 and 7153.

**THIS PAGE WAS
INTENTIONALLY LEFT
BLANK**

4. Service

The Series xx70000 coaxial relay modules are reliable assemblies needing no regular service. If a component within the coaxial relay module assembly fails, such as a reed relay or interface/driver board, contact Technical Support for assistance.

For ordering coaxial relay modules, all xx70000 part numbers are prefaced with "U"

Universal Switching Corporation
7671 North San Fernando Road
Burbank, CA 91505-1073 USA

Technical Support +1 818 381-5111

Email: support@uswi.com



NOTE: Additional information is available at www.uswi.com

**THIS PAGE WAS
INTENTIONALLY LEFT
BLANK**

5. General Specifications

- Configuration 2x1 up to 24x1 I/O configurations
- User connectors Top location, BNC (standard)
- Frequency range DC to 800MHz (depending on model number)
- Impedance 50 ohm standard, 75 ohm optional
- Switching speed 1ms for dry contacts; 3ms for mercury wetted contacts
- Contact resistance 300 mOhm; 100 mOhm for mercury wetted contacts
- Contact rating 100VDC, 0.25A, 10W (4VDC Max on self-terminating type -25, -27, -65, -67)
- Coil resistance 1K ohms std; 250 & 500 Ohms optional
- Coil current 28mA std (1K coil) per activated port
- Dielectric Withstanding >500VDC (50% Relative Humidity)
- Connector BNC (standard), F-type, SMA, TNC optional on some models
- Power requirement +15VDC, 0.6A on RS70000 / E70000 Series
+12VDC for URS79000-12846A model
+24 to +28VDC standard on 70000 Series
- Size Dependent on Nx1 configuration
- Unit material Aluminum alloy, corrosion resistant
- Operation temp range -34C to +65C
- Storage temp range -40C to +85C

5.1. Typical Isolation

Model	1MHz	10MHz	100MHz	100-300MHz	300-600MHz
xx71xxx	80dB	65dB	45dB		
xx72xxx	95dB	75dB	55dB		
xx73xxx	105dB	85dB	65dB		
xx74xxx*	160dB	140dB	120dB	80dB	60dB
xx76xxx*	140dB	120dB	100dB		
xx77xxx	90dB	70dB	50dB		
xx79xxx	90dB	70dB	50dB		

*not avail with I or IS option

5.2. Insertion Loss – 2 throws to 24 throws

Model	<1dB Frequency Range	<3dB Frequency Range
U7xx02	DC - 700MHz	DC - 800MHz
U7xx04	DC - 338MHz	DC - 419MHz
U7xx08	DC - 166MHz	DC - 214MHz
U7xx12	DC - 110MHz	DC - 144MHz
U7xx16	DC - 82MHz	DC - 108MHz
U7xx24	DC - 54MHz	DC - 72MHz

6. Record of Changes

This section only applies to revised manuals. The table below indicates the revision level entered and a brief description of change(s) incorporated into the manual.

Revision	Description of Change	Date
A	Revised manual to include typical control cable for RS70000 series relays. Section includes wiring diagram.	20100716
B	Added T and L extra options to model number designations, rearranged specification layout. Added mounting hole dimensions.	20101206
C	Added description for the Qnn command.	20141022
D	Corrected description for the Qnn command.	20150203
E	Added Dielectric Withstanding Rating. Updated cover page and added pictures.	20150211
F	Updated manual for URS79000-12846A model: Updated Section 3.2.3, 3.2.4, 0, and 3.2.6	20160302
G	Added "C" option for normally closed in relay part number suffix.	20160428
H	Added provisions for the E70000 series	20200429